

MULTILAYER CERAMIC CHIP CAPACITORS(MLCC)

Features

- Various temperature characteristics a wide range in small size.
- Mounted either by flow soldering methods.
- Excellent dielectric strength due to uniform structure of dielectric layers.
- 500v~3000VDC high voltage application.

Applications

- MLCC are becoming increasingly important key electronic applications, which are helpful in reducing the size of electronic circuitry.
- MLCC are used extensively in computers, communicative products, and the detail applications which including the following:
 - By-Passing of an AC Signal
 - Frequency Discrimination
 - Transient Voltage and Are Suppression
 - Surge Protection

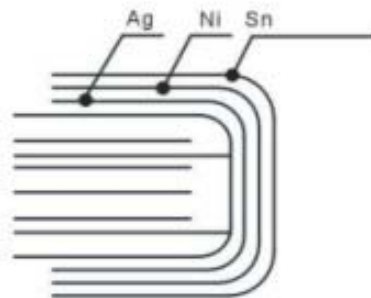

Construction of MLCC

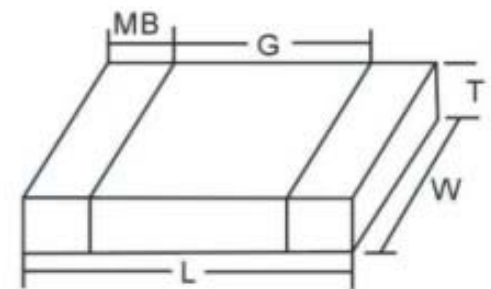
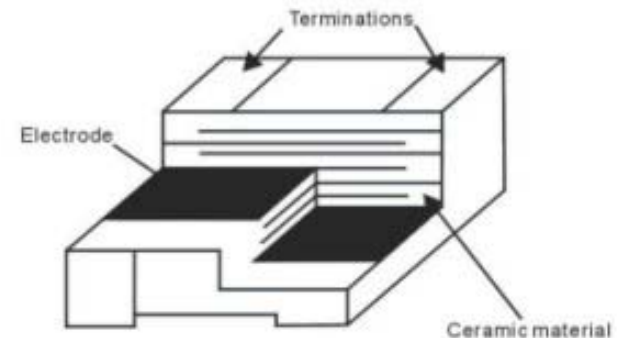

Part Number Code



Size Code

Size Code	L	W	T	MB	G(min)
0201	0.60±0.05	0.30±0.05	S:0.50±0.20	0.10-0.20	0.2
0402	1.00±0.05	0.50±0.05	S:0.50±0.10	0.15-0.35	0.3
0603	1.60±0.15	0.80±0.12	P:0.75±0.30	0.27-0.60	0.5
0805	2.0±0.2	1.25±0.20	S:0.60±0.20	0.30-0.70	0.7
			M:0.75±0.20		
			H:0.95±0.30		
			X:1.30±0.30		
1206	3.2±0.2	1.60±0.20	S:0.60±0.20		
			M:0.75±0.20		

Unit:mm

1210	3.2±0.2	2.5±0.2	H:0.95±0.30 X:1.30±0.30 L:1.80±0.40	0.30~0.70	1.5		
1808	4.5±0.3	2.0±0.20	X:1.30±0.30 F:1.60±0.40 Z:2.00±0.40	0.35~0.95	0.2		
1812	4.5±0.3	3.2±0.3	X:1.30±0.30 F:1.60±0.40 Z:2.00±0.40	0.35~1.00	2.0		
2220	5.7±0.5	5.0±0.5	F:1.60±0.40 Z:2.00±0.40	0.35~1.2	3.0		
2225	5.7±0.5	6.3±0.5	E:2.50±0.40	0.35~1.2	3.0		
3035	7.6±0.5	9.0±0.5	A:3.00±0.50	0.5~1.5	3.5		
Temperature Characteristic							
Code	N		B		Y E		
Dielectric type	COG		X7R/X5R		Y5V Z5U		
Temp. range	-55~125℃		-55~125℃/-55~85℃		-30~85℃ +10~85℃		
Cap. chang	0±60-250ppm		±15%		+22~-82% +22~-56%		
Capacitance (Example) *Two significant figures followed by number of zero. 102=1000pF							
Code(EIA code)	Cap.(pF)		Code(EIA code)		Cap.(pF)		
0R5	0.5		101		100		
2R0	2.0		102		1000(1nF)		
100	10		105		1,000,000(1uF)		
Capacitance Tolerance *Tolerances may be restricted by dielectric type							
Product or capacitance	NPO,C<10pF						
Code	A	B	C	D			
Tolerance	±0.05pF	±0.10pF	±0.25pF	±0.50pF			
Product or capacitance	NPO,C>10pF						
Code	F	G	J	K			
Tolerance	±1.0%	±2.0%	±5.0%	±10%			
Product or capacitance	X7R		Y5V		Z5U		
Code	J	K	M	M	Z		
Tolerance	±5.0%	±10%	±20%	±20%	-20~+80%		
Voltage							
Code	OJ	1A	1C	1E	1H	2A	2E
Rated Voltage	6.3VDC	10VDC	16VDC	25VDC	50VDC	100VDC	250VDC(AC)
Code	2D	2H	2J	3A	3D	3F	3G
Rated Voltage	200VDC	500VDC	630VDC	1KVDC	2KVDC	3KVDC	4KVDC
Termination							
N=Nickel barrier S=Silver(option) T=Nickel barrier with 100% Tin (option)							
Termination							
B=Bulk 5=500pcs/Reel, 1=1K/Reel,2=2KReel,3=3K/Reel (for plastic tape only) T=4K/Reel U=10K/Reel,S=15K/Reel V=16K/Reel W=20K/Reel							

NPO Capacitance Range

SIZE	NPO																											
	0201		0402		0603		0805		1206		1210		1808		1812		2220		2225		3035							
Cap	25	50	25	50	25	50	100	250	25	50	100	250	25	50	100	250	50	100	250	50	100	250	50	100	250	50	100	250
Vr	EIA																											

10000	103								X	X			X	L		X	Z	Z	X	F	Z	F	E	E	X	X	F	X	X	F		X	X
12000	123															X			F	Z	E	F	E	E	X	F	E	X	F	E		X	X
15000	153												L			L	Z		F	Z		F	E	E	X	F	E	X	F	E		X	X
18000	183															F			F	E		F	E		F	F	E	F	F	E		X	F
22000	223												L			Z	Z		Z	E		F	E		F	E	E	F	E	E	X	X	F
27000	273																	Z				E	E		F	E		F	E		X	F	E
33000	333															Z			E			E	E		F	E		F	E		X	F	E
47000	473																	E				E			E		E				F	F	A
56000	563																								E		E				F	E	
68000	683																														E	A	
82000	823																														E		
100000	104																														A		

NPO Capacitance range (High voltage series)

SIZE		NPO																														
		0805		1206			1210			1808					1812					2225					3035							
Vr		500V	1KV	500V	1KV	2KV	3KV	500V	1KV	2KV	3KV	500V	1KV	2KV	3KV	4KV	500V	1KV	2KV	3KV	4KV	500V	1KV	2KV	3KV	4KV	500V	1KV	2KV	3KV	4KV	
Cap (pF)	EIA																															
3.9	3R9	H	H	H	H	H	H				H																					
7	7	H	H	H	H	H	H				H																					
10	100	H	H	H	H	H	H		H	H	H		F	F	F	F		F	F	F	F					F	F					
12	120	H	H	H	H	H	H		H	H	H		F	F	F	F		F	F	F	F					F	F					
15	150	H	H	H	H	H	H		H	H	H		F	F	F	F		F	F	F	F					F	F					
18	180	H	H	H	H	H	H		H	H	H		F	F	F	F		F	F	F	F					F	F					
22	220	H	H	H	H	H	H		H	H	H		F	F	F	F		F	F	F	F					F	F					
27	270	H	H	H	H	H	H		H	H	H		F	F	F	F		F	F	F	F					F	F					
33	330	H	H	H	H	H	H		H	H	H		F	F	F	F		F	F	F	F					F	F					
39	390	H	H	H	H	H	H		H	H	H		F	F	F	F		F	F	F	F					F	F					
47	470	H	H	H	H	H	X		H	H	H		F	F	F	F		F	F	F	F					F	F					
56	560	H	H	H	H	H	X		H	H	H		F	F	F	F		F	F	F	F					F	F					
68	680	H	H	H	H	H	X		H	H	H		F	F	F	E		F	F	F	F					F	F					
82	820	H	H	H	H	H	X		H	H	H		F	F	F	E		F	F	F	F					F	F					
100	101	X	X	H	X	X	X		H	H	F		F	F	F	E		F	F	F	F					F	F	F				F
120	121	X	X	H	X	X			H	H	F		F	F	F			F	F	F	F					F	F	F				F
150	151	X	X	H	X	X			H	H	F		F	F	F			F	F	F	F					F	F	F				F
180	181	X	X	H	X	X			H	H	F		F	F	F			F	F	F	E					F	F	F				F

220	221	X	X	X	X	X	H	H	H	F	F	F	F	F	F	F	E	F	F	F	F	F					
270	271	X	X	X	X	X	H	H	X		F	F	F		F	F	F	E	F	F	E	F					
330	331	X	X	X	X	X	H	H	X		F	F	F		F	F	F	E	F	F	E	F					
390	391	X	X	X	X	X	H	H	X		F	F	F		F	F	F	A	F	F	E	F					
470	471	X	X	X	X	X	H	H	X		F	F	F		F	E	E	A	F	F	E	F					
560	561	X	X	X	X		H	H	F		F	F	F		F	E	E	A	F	F	A	F					
680	681	X	X	X	X		H	H	F		F	F	E		F	E	E	A	F	E	A	E					
820	821	X	X	X	X		H	H			F	F	E		F	E	A		F	E		E					
1000	102	X	X	X	X		H	H			F	E	E	E	F	E	E	A	F	F	E	E	A	F	F	F	A
1200	122	X		X	X		X	X			F	E	E		F	E	A		F	F	E	A		F	F	F	
1500	152	X		X	X		X	X			F	E	E		F	E	A		F	F	E	A		F	F	F	
1800	182	X		X	X		X	X			F	E	E		F	E	A		F	F	E			F	F	F	
2200	222	X		X	X		X	X			F	E	E		F	E	A		F	F	E			F	F	F	
2700	272			X			F	F			F	E			F	E			F	E	A			F	E	E	
3300	332			X			F	F			F	E			E	E			F	E	A			F	E	E	
3900	392			X			F				E				E	A			F	E				E	E	A	
4700	472			X			F				E				E	A			F	E				F	E	A	
5600	562										E				E				E	A				F	E	A	
6800	682										E				A				E	A				F	E	A	
8200	822										E				A				A					E	A		
10000	103										E				A				A					E	A		
12000	123																							E			
15000	153																							E			
18000	183																							E			
22000	223																							E			
27000	273																							E			
33000	333																							E			
39000	393																							E			
47000	473																							E			

No	Item	Test Method	Specification		
			Dielectric	Temperature Range	Capacitance Change
		(a) NPO The temperature coefficient is determine during the capacitance measured in step 3 as a reference. When cycling the temperature sequentially from step 1 through 5. The capacitance shall be within the specified tolerance for the temperature coefficient.	NPO	-55°C to +125°C	0 ± 60 ppm/°C

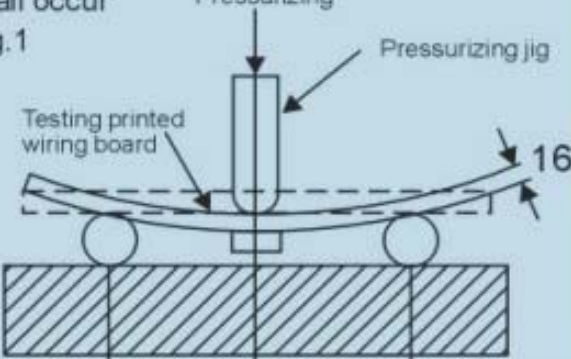
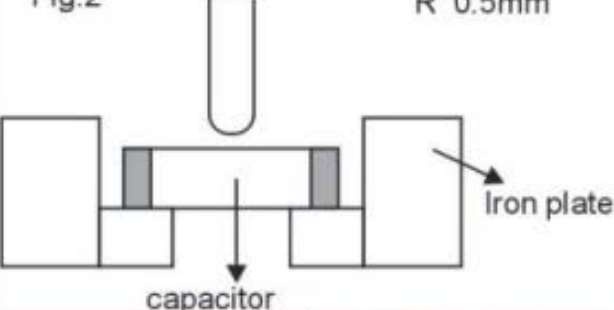
15	Capacitance Temperature Characteristic	<table border="1" data-bbox="558 61 1167 483"> <thead> <tr> <th>Step</th> <th>Temperature(°C)</th> </tr> </thead> <tbody> <tr> <td>1</td> <td>+25±2°C</td> </tr> <tr> <td>2</td> <td>-55±3°C</td> </tr> <tr> <td>3</td> <td>+25±2°C</td> </tr> <tr> <td>4</td> <td>+125±3°C (for NPO/X7R) +85±3°C (for X5R/Y5V/Z5U)</td> </tr> <tr> <td>5</td> <td>+25±2°C</td> </tr> </tbody> </table> <p data-bbox="499 496 1247 646">(b) X7R, X5R, Y5V, Z5U The ranges of capacitance change compared with the 25±2°C value over the temperature range shall be within the specified ranges.</p>	Step	Temperature(°C)	1	+25±2°C	2	-55±3°C	3	+25±2°C	4	+125±3°C (for NPO/X7R) +85±3°C (for X5R/Y5V/Z5U)	5	+25±2°C	<table border="1" data-bbox="1314 38 1967 652"> <tbody> <tr> <td>X7R</td> <td>-55°C to +125°C</td> <td>Within 15%</td> </tr> <tr> <td>X5R</td> <td>-55°C to +85°C</td> <td>Within 15%</td> </tr> <tr> <td>Z5U</td> <td>+10°C to +85°C</td> <td>Within +22%~-56%</td> </tr> <tr> <td>Y5V</td> <td>-30°C to +85°C</td> <td>Within +22%~-82%</td> </tr> </tbody> </table>	X7R	-55°C to +125°C	Within 15%	X5R	-55°C to +85°C	Within 15%	Z5U	+10°C to +85°C	Within +22%~-56%	Y5V	-30°C to +85°C	Within +22%~-82%
Step	Temperature(°C)																										
1	+25±2°C																										
2	-55±3°C																										
3	+25±2°C																										
4	+125±3°C (for NPO/X7R) +85±3°C (for X5R/Y5V/Z5U)																										
5	+25±2°C																										
X7R	-55°C to +125°C	Within 15%																									
X5R	-55°C to +85°C	Within 15%																									
Z5U	+10°C to +85°C	Within +22%~-56%																									
Y5V	-30°C to +85°C	Within +22%~-82%																									
16	Resistance to Board Bending	<p data-bbox="558 688 1138 1071">Mount the capacitor to the testing print wiring board. Then apply force in the direction shown in Fig.1. The bending stroke shall be more than 1mm. Pressuring is carried out at the rate of 1mm/s. After reaching the specified bending. Keeping it for 5±1 seconds then measure the capacitance value. The capacitance could not be lower 5% of the initial value</p>	<p data-bbox="1331 688 1940 792">No cracking or marking defects shall occur Unit:mm Fig.1</p>  <p>The diagram shows a testing printed wiring board supported by two rollers on a base. A pressurizing jig is positioned vertically above the board, with an arrow indicating downward force. A curved arrow labeled '16' indicates the bending stroke of the board.</p>																								
17	Chip Break Strength	<p data-bbox="558 1192 1138 1419">Place the capacitor on an iron plate, then gradually apply a load on the center of the chip until it breaks. Tip of push-pull gauge is shown in Fig.2</p>	<p data-bbox="1356 1136 1940 1208">To load 2 kg at least. Φ 1.0mm Fig.2 R 0.5mm</p>  <p>The diagram shows a capacitor placed on an iron plate. A push-pull gauge is positioned above the capacitor, with an arrow indicating downward force. The gauge has a cylindrical tip with a diameter of 1.0mm and a radius of 0.5mm.</p>																								
No	Item	Test Method	Specification																								

18	Temperature Cycle	Mount the capacitor on test board, then cycling the temperature sequentially from step 1 to step 5, and perform 25 cycles.					No crack and electric failure	
		Step	NPO	X7R	X5R	Z5U		Y5V
			Temperature(°C) / time(min)		Temperature(°C) / time(min)			
		1	+25±2°C / 3±1		+25±2°C / 3±1			
		2	-55±2°C / 30±3		-30±2°C / 30±3 (Z5U IS +10±2°C/X5R IS -55±2°C)			
		3	+25±2°C / 3±1		+25±2°C / 3±1			
		4	+125±3°C / 30±3		+85±3°C / 30±3			
5	+25±2°C / 3±1		+25±2°C / 3±1					
Remove and let sit for 24±2hours(NPO) or 48±4hours(X7R,X5R,Z5U,Y5V) at room temperature(25°C),then measure.								

Packing

- Bulk Packaging : Packing code (B)
- Tape Packaging : Please specify the packing code when ordering.

Packing Code	Pcs /Reel	Reel size	
5	500	7"	
1	1000	7"	
2	2000	7"	
3	3000	7"	
T	4000	7"	
U	10000	0402	7"
		0603	10"
S	15000	13"	
V	16000	13"	
W	20000	13"	

■ Appearance of Taping



Top tape: 50+10µ in thickness

■ Dimension of paper Tape

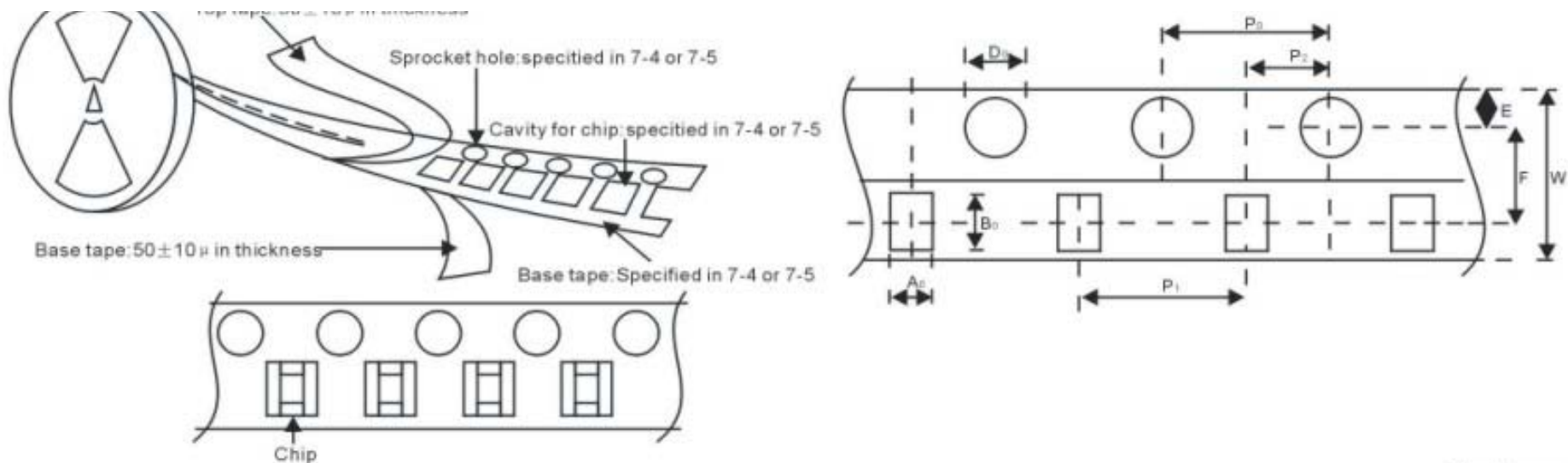

Mark	Chip size	0201	0402	0603	0805	1206	1210	1808	1812	2211	2220	2225	3035	tolerance
		A_0 (width of compartment)	0.4	0.63	1	1.5	1.85	2.9	2.4	3.6	5.5	6.7	9.3	±0.1
B_0 (length of compartment)	0.63	1.13	1.8	2.25	3.45	3.6	4.9	4.9	6.0	7.9	±0.1			
W (tape width)	8	8	8	8	8	8	12	12	12	16	16	±0.3		
E (distance between a sprocket hole and upper)	1.75	1.75	1.75	1.75	1.75	1.75	1.75	1.75	1.75	1.75	1.75	±0.1		
F (distance between centers of a sprocket and chip hole)	3.2	3.5	3.5	3.5	3.5	3.5	5.5	5.5	5.5	7	7	±0.1		
D_0 (diameter of sprocket hole)	1.55	1.55	1.55	1.55	1.55	1.55	1.55	1.55	1.55	1.55	1.55	±0.1		
P_1 (compartment pitch)	2	2	4	4	4	4	8	8	8	12	12	±0.1		
P_0 (distance between centers of compartment hole and chip hole)	1	1	2	2	2	2	4	4	4	6	6	±0.1		
P_2 (Sprocket hole pitch)	2	2	4	4	4	4	8	8	8	12	12	±0.1		

- Paper thickness T : 0.65 ± 0.05 mm (for 0402 product)
- Paper thickness T : 0.75 ± 0.05 mm (for thickness code S)
- Paper thickness T : 0.95 ± 0.05 mm (for thickness code : P、M、H)
- Note : (1). The top tape and bottom tape shall not protrude beyond the edges of the tape, and shall not cover sprocket holes

■ Note : (2). Cumulative tolerance of sprocket holes 10 pitch : $\pm 0.3\text{mm}$

Dimensions of Embossed Packing(plastic tape)

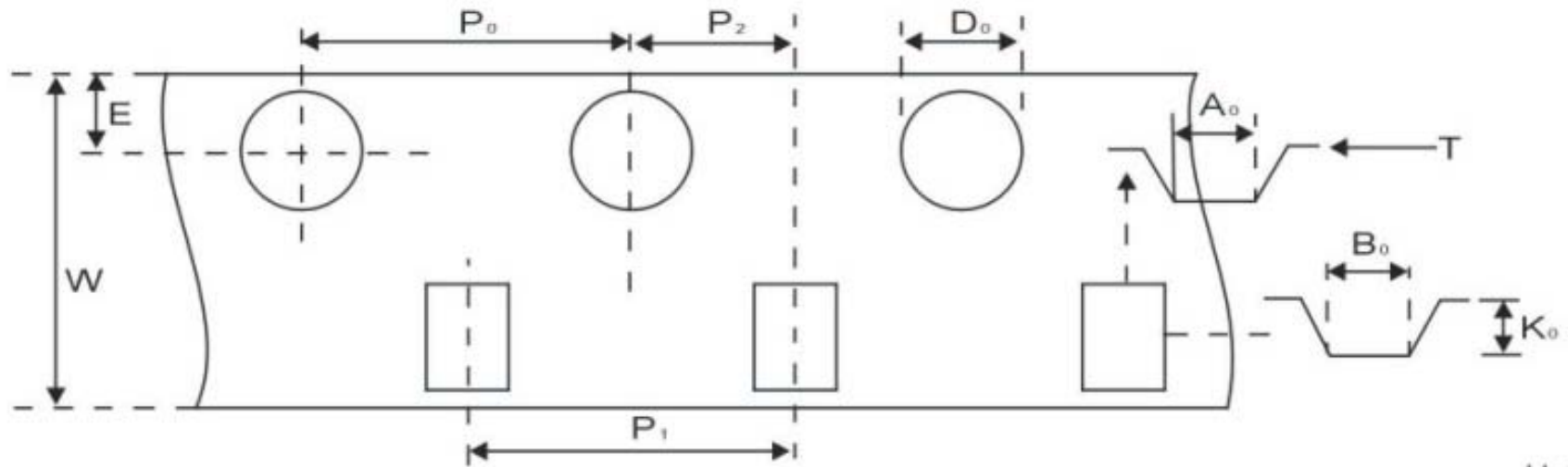

Unit:mm

Mark	Chip size	0201	0402	0603	0805	1206	1808	1812	2225	3035			
A_0 (width of compartment)		0.3 ± 0.1	0.63 ± 0.1	1.0 ± 0.15	1.5 ± 0.2	1.85 ± 0.2	2.3 ± 0.2	3.4 ± 0.2	6.7 ± 0.3	9 ± 0.3			
B_0 (length of compartment)		0.55 ± 0.1	1.13 ± 0.1	1.8 ± 0.15	2.3 ± 0.2	3.5 ± 0.2	4.8 ± 0.2	4.8 ± 0.2	6.0 ± 0.3	8 ± 0.3			
K_0 (depth of compartment)		0.6 ± 0.3	1.0 ± 0.3	1.0 ± 0.3	1.4 ± 0.3	X	1.5 ± 0.2	X	1.4 ± 0.2	X	1.4 ± 0.2	F	1.7 ± 0.2
	F					1.7 ± 0.2	F	1.7 ± 0.2	F	1.7 ± 0.2	Z	2.2 ± 0.2	
	Z					2.2 ± 0.2	Z	2.2 ± 0.2	Z	2.2 ± 0.2	E	2.7 ± 0.2	
	E					2.7 ± 0.2	E	2.7 ± 0.2	E	2.7 ± 0.2	A	3.2 ± 0.3	
D_0 (diameter of sprocket hole)		1.55 ± 0.1	1.55 ± 0.1	1.55 ± 0.1	1.55 ± 0.1	1.55 ± 0.1	1.55 ± 0.1	1.55 ± 0.1	1.55 ± 0.2	1.55 ± 0.2			
W (tape width)		8.0 ± 0.2	8.0 ± 0.2	8.0 ± 0.2	8.0 ± 0.2	8.0 ± 0.2	12.0 ± 0.2	12.0 ± 0.2	12.0 ± 0.2	12.0 ± 0.2			
P_1 (compartment pitch)		2.0 ± 0.1	2.0 ± 0.1	4.0 ± 0.1	4.0 ± 0.1	4.0 ± 0.1	4.0 ± 0.1	8.0 ± 0.1	8.0 ± 0.1	8.0 ± 0.1			
P_z (distance between centers of compartment hole and chip hole)		1.0 ± 0.1	1.0 ± 0.1	2.0 ± 0.1	2.0 ± 0.1	2.0 ± 0.1	2.0 ± 0.1	2.0 ± 0.1	2.0 ± 0.1	2.0 ± 0.1			
E (distance between a sprocket hole and upper)		1.75 ± 0.1	1.75 ± 0.1	1.75 ± 0.1	1.75 ± 0.1	1.75 ± 0.1	1.75 ± 0.1	1.75 ± 0.1	1.75 ± 0.1	1.75 ± 0.1			
T (tape thickness)		0.25 ± 0.1	0.25 ± 0.1	0.25 ± 0.1	0.25 ± 0.1	0.25 ± 0.1	0.25 ± 0.1	0.25 ± 0.1	0.25 ± 0.1	0.25 ± 0.1			
H (Sprocket hole pitch)		2.0 ± 0.1	2.0 ± 0.1	4.0 ± 0.1	4.0 ± 0.1	4.0 ± 0.1	4.0 ± 0.1	4.0 ± 0.1	4.0 ± 0.1	4.0 ± 0.1			

Emboss tape: for thickness code X,F,L,Z,E

Dimension of Reel

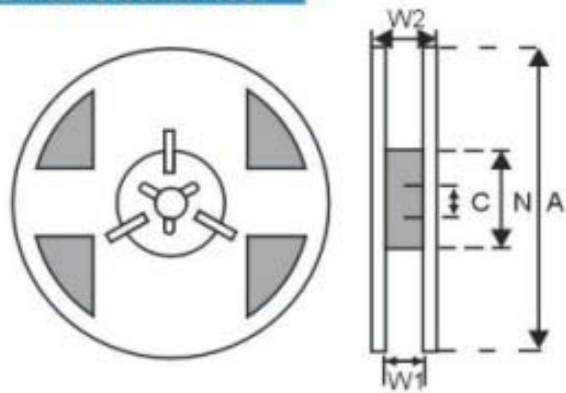

Unit:mm

Reel size	A	N	C	W1	W2(max.)
7"	179±2	60±2	13.0±0.5	9.4±1.0	14.4
7"	179±2	60±2	13.0±0.5	12.0±0.5*	16.0
10"	254±2	100±2	13.0±0.5	9.5±1.0	14.4
13"	330±2	100±2	13.0±0.5	9.5±1.0	14.4

*Plastic Tape

Reference data

CAPACITANCE-TEMPERATURE CHARACTERISTICS

Measuring Condition NPO : 1MHz, 1Vr. m. s.
X7R, X5R, Z5U, Y5V: 1KHz 1Vr. m. s.

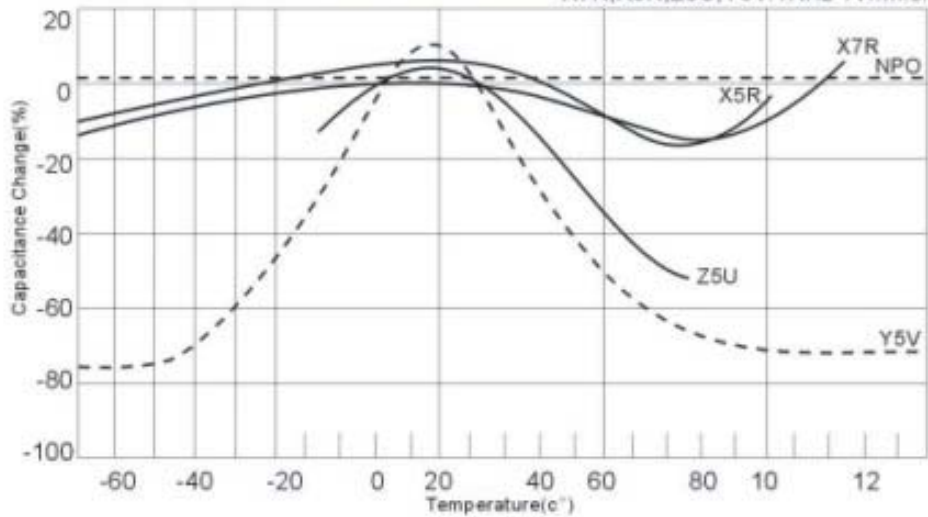

CAPACITANCE-TEMPERATURE CHARACTERISTICS

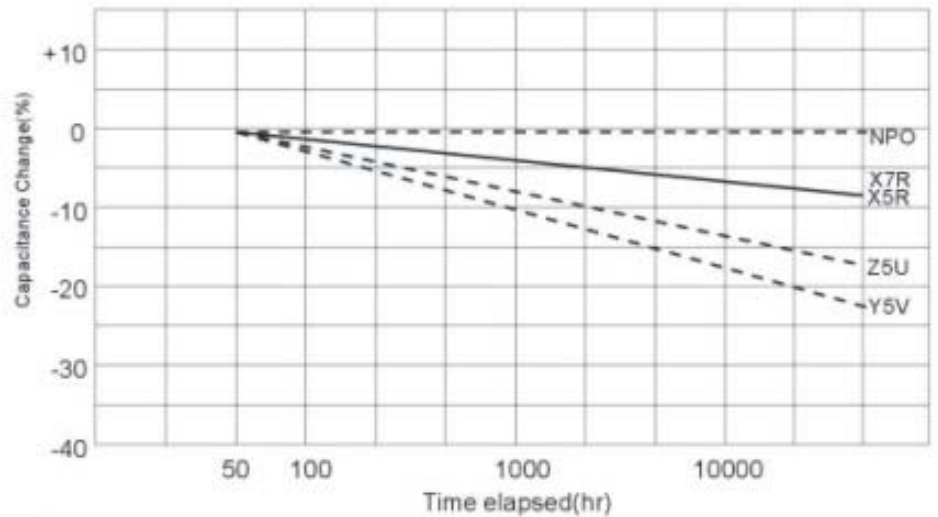

Advised Soldering Profile (Prevention of thermal shock)

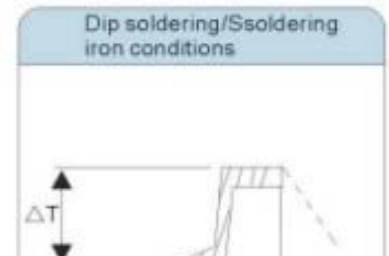
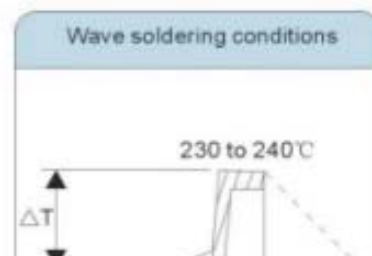
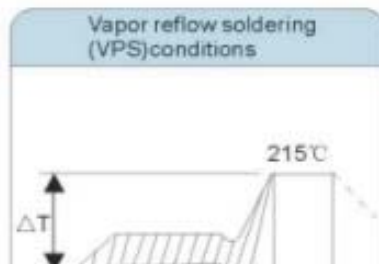
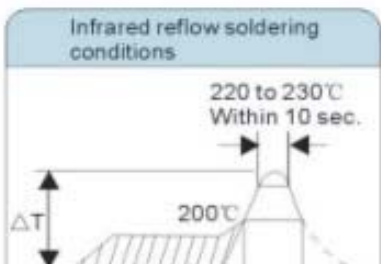

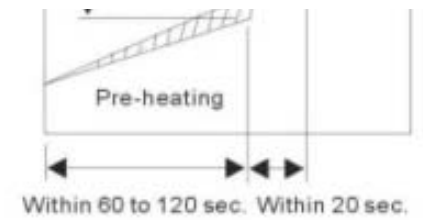
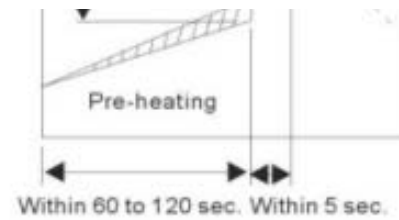
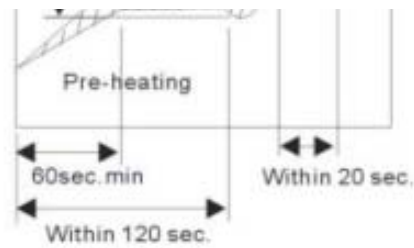
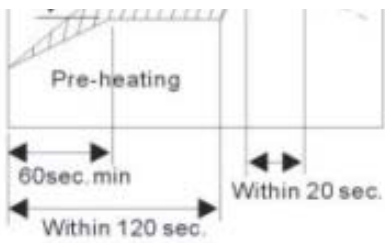

NOTES:

- Carefully perform pre-heating so that the temperature difference (ΔT) between the color and component surface should be within the range.
- Do not allow the iron-tip to directly touch the ceramic element.

ΔT	Chip size
120°C	3.2 × 1.6mm max

PCB Design

Chip components are susceptible to board stress since the component itself is mounted directly on the board. They are also sensitive to mechanical and thermal stress when solder, which may cause chip cracked. Please take solder from and component layout into consideration to eliminate stress.

Pattern Form

Placing of chip components and component.

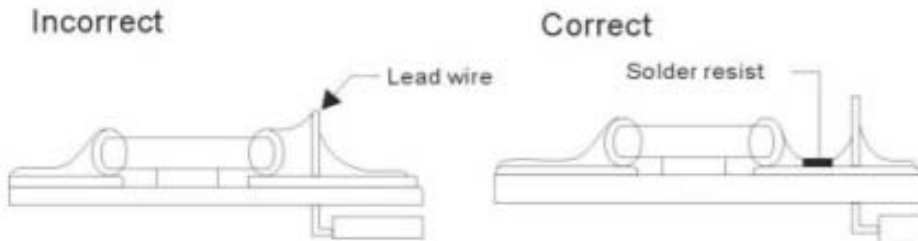

Placing of close to chassis.

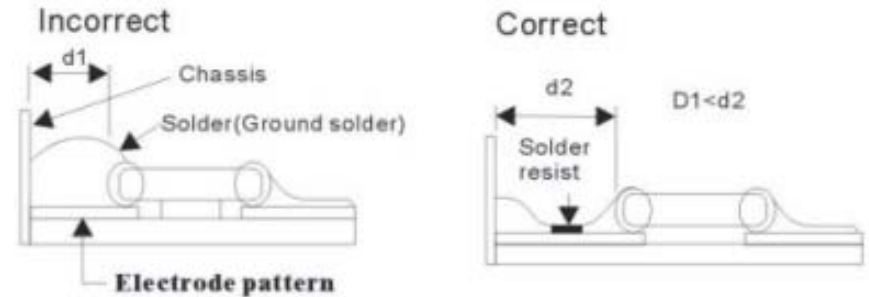

Placing leaded components after chip component.

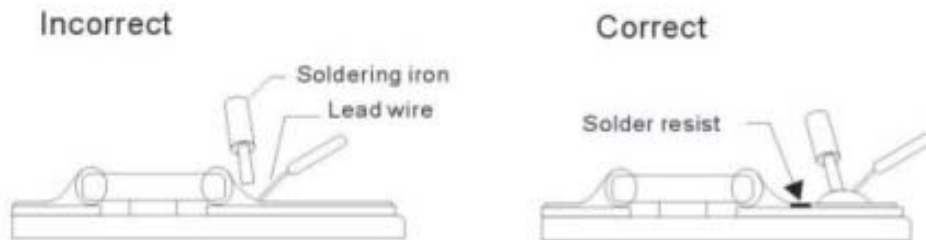

Lateral mounting



Component Direction

To design a mounting position that minimizes the stress imposed on the chip during flexing or bending of the board.

Put the component lateral to the direction in which stress acts.

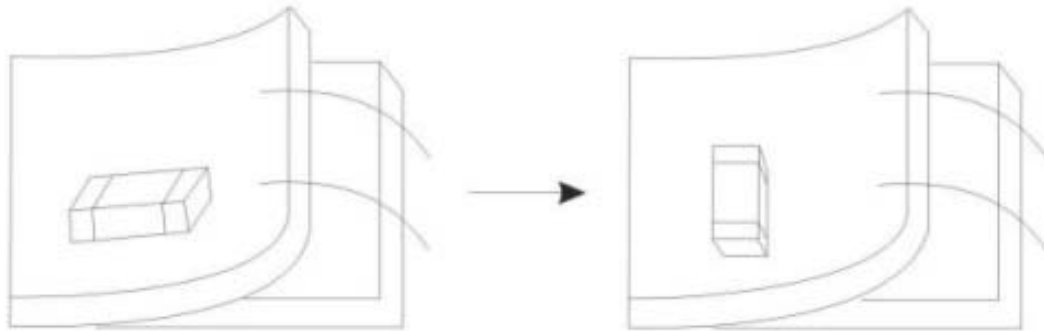

Component layout close to board separation point. Susceptibility to stress in the order: $A > C > B = D$

